

**HOKKAIDO**

**SPLIT TYPE, HEAT PUMP AIR CONDITIONERS**

# **Technical & service manual 2005**

**HKEI-HCNI 262-352 G Health Care**

R410a Wall Mounted

# Health Care Series (R410A)

## Contents

1. Features.....	02
2. Specification.....	03
3. Dimensions.....	05
4. Refrigeration cycle diagram.....	09
5. Pressure table.....	10
6. Capacity table.....	14
7. Wiring diagram.....	20
8. Electronic function.....	25
9. Troubleshooting.....	33
10. Characteristic of temp. sensor.....	36

## 1.Features

1.1 Compact design

1.2 High efficiency and quiet operation

1.3 A class energy level

Model			HKEI-HCNI 262 G	HKEI-HCNI 352 G	
Power supply		Ph-V-Hz	1, 220-240V~, 50Hz	1, 220-240V~, 50Hz	
COOLING	Capacity	W	2640	3520	
	Input	W	820	1080	
	Rated current	A	3,60	5,00	
	EER	W/W	3,22	3,26	
HEATING	Capacity	W	3220	4400	
	Input	W	890	1180	
	Rated current	A	3,60	5,30	
	COP	W/W	3,62	3,73	
Moisture Removal		L/h	1,00	1,20	
Max. input consumption		W	1200	1550	
Max. current		A	5,30	10	
Starting current		A	21	30	
COMPRESSOR	Model		PA108X1C-4FTDE	PA140X2C-4FT	
	Type		Rotary	Rotary	
	Brand		TOSHIBA	TOSHIBA	
	Capacity	Btu/h	9000	12000	
	Input	W	920	1200	
	Thermal protector		MRA13430-9087	UP3RE0591-T56	
	Capacitor	uF	25	35	
	Refrigerant oil	ml	330	480	
	Model		RPG13H	RPG13D	
	Brand		Welling	Welling	
	Input	W	39,50	44	
	Capacitor	uF	1,20	1,20	
	Speed(hi/mi/lo)	r/min	1200/950/850	1220/1000/800	
	Indoor air flow (Hi/Mi/Lo)		m3/h	500/430/370	600/520/420
Indoor noise level (Hi/Mi/Lo)		dB(A)	37/34/31	40/37/34	
INDOOR	Dimension (W*H*D)		mm	710×250×195	790×265×193
	Packing (W*H*D)		mm	800×340×270	875×285×375
	Net/Gross weight		Kg	8/10	9/11
	Model			YDK24-6F	YDK24-6F
	Brand			Welling	Welling
	Input	W	56	56	
	Capacitor	uF	2,50	2,50	
	Speed	r/min	800	800	
Outdoor air flow		m3/h	1800	1900	
Outdoor noise level		dB(A)	50	50	
OUTDOOR	Dimension(W*H*D)		mm	780X540X250	780X540X250
	Packing (W*H*D)		mm	910X575X335	910X575X335
	Net/Gross weight		Kg	37/40	38/41
Refrigerant type R410A		g	920	1080	
Design pressure		MPa	4,20	4,20	
REFR. PIPING	Liquid side/ Gas side	mm(inch)	6.35/ 9.53	6.35/ 12.7	
	Max. refrigerant pipe length	m	10	10	
	Max. difference in level	m	5	5	
Connection wiring			No	No	
Plug type			16A	16A	
Thermostat type			Electronic control	Electronic control	
Operation temp			17-30	17-30	
Ambient temp			-7 -- 45	-7 -- 45	

3. Dimensions  
3.1 Indoor unit  
HKEI 262 G

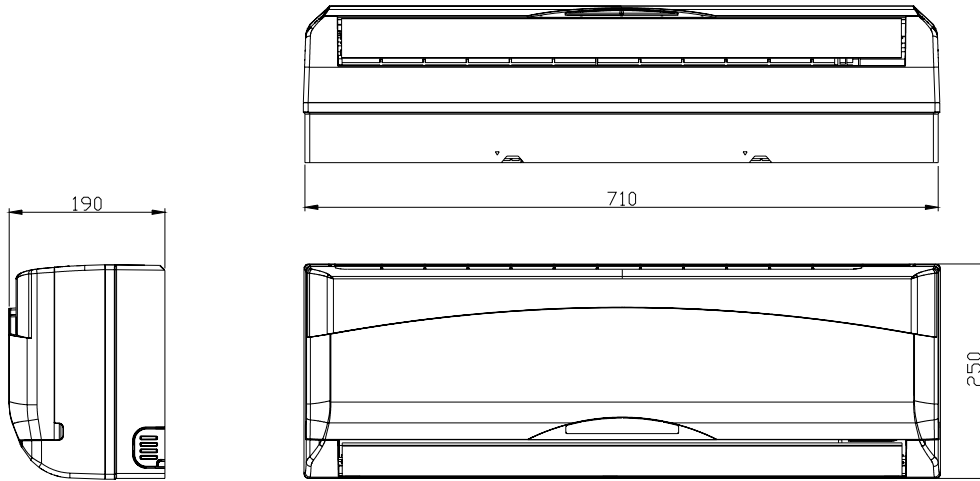

3.2 Indoor unit  
HKEI 352 G

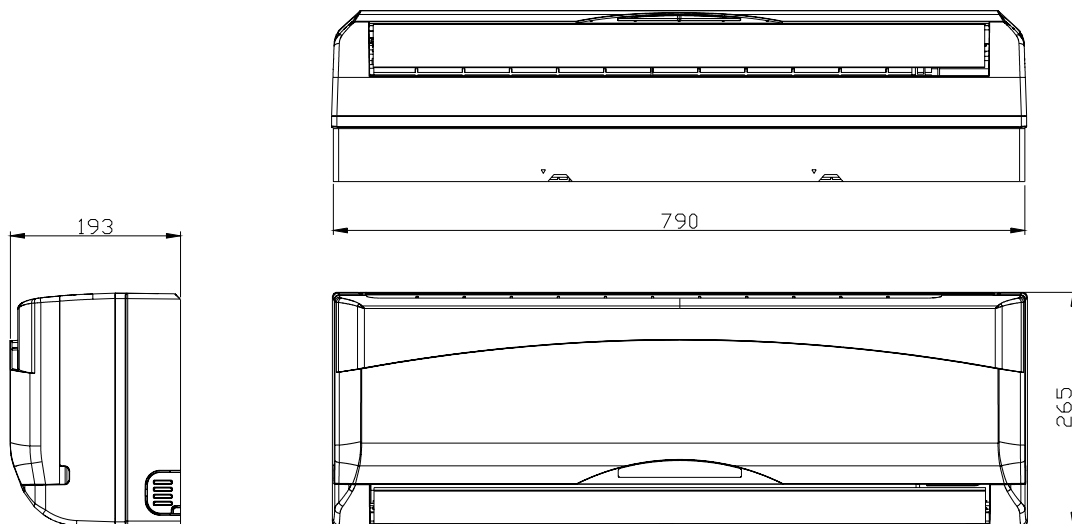

### 3.4 Outdoor unit

HCNI 262-352 G

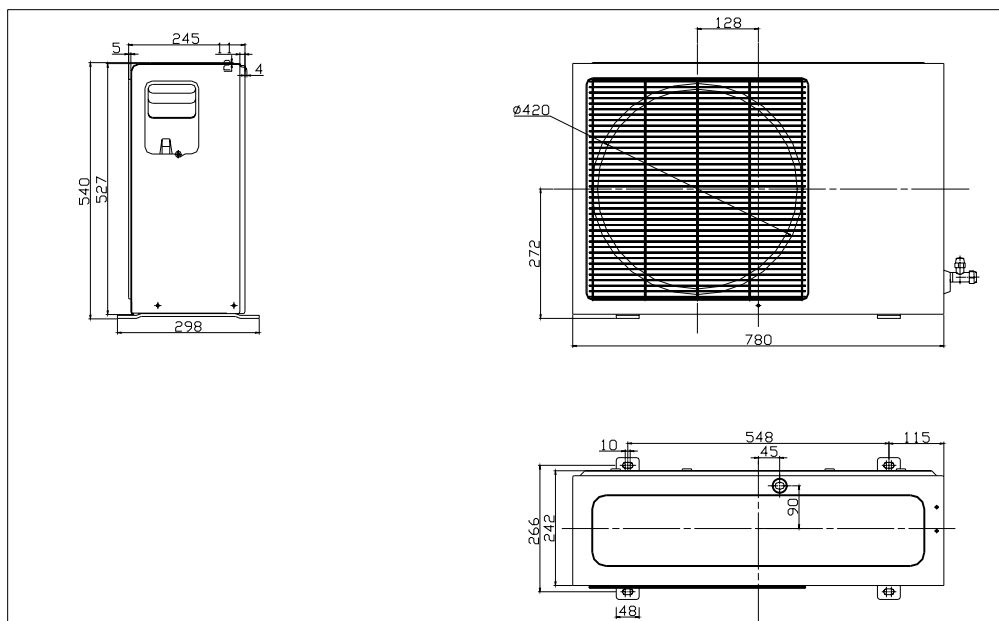

#### 4.Refrigeration cycle diagram

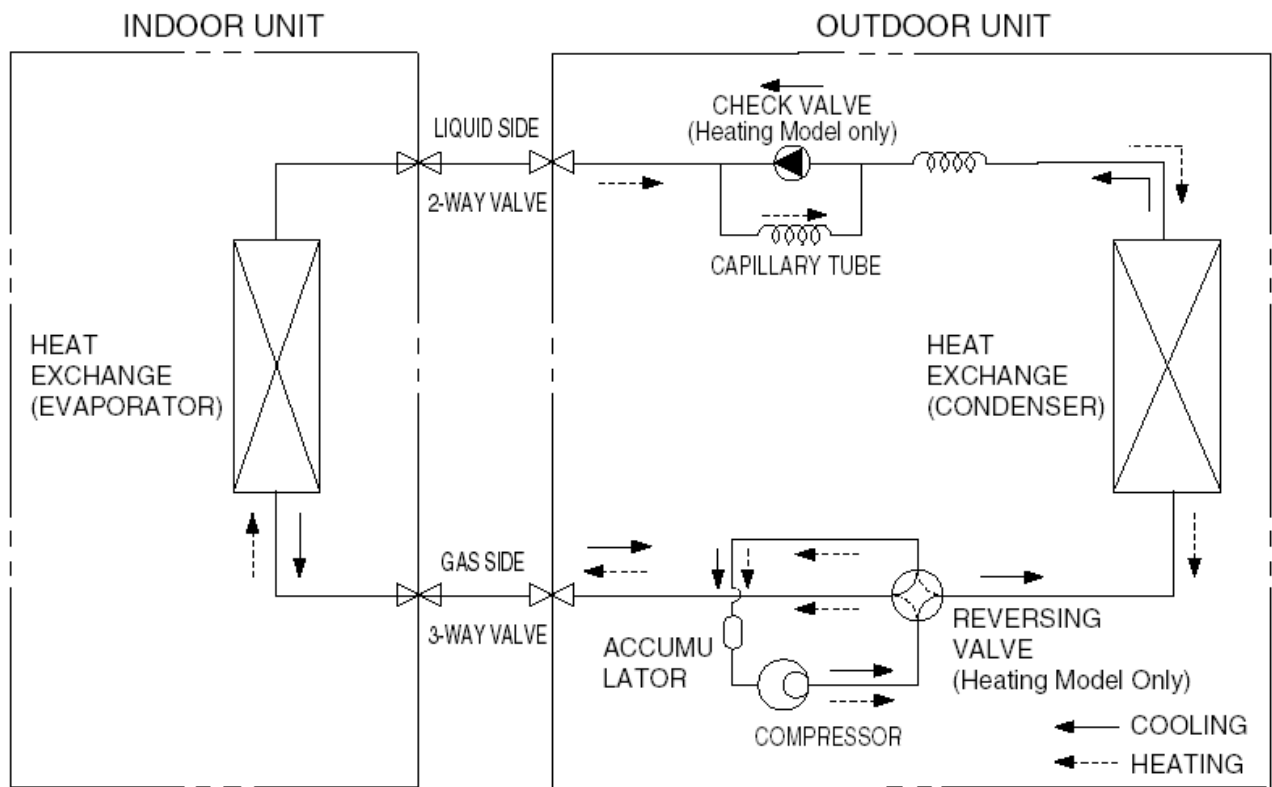

## 5. Pressure table

Note:

\*The pressure data is from 3 way valve, the pressure data are pressure above atmosphere.

\*D: Dry bulb temp.

\*W: Wet bulb temp.

### 5.1 HCNI 262 G

Cooling mode		Outdoor temperature (Dry bulb temp)					
Indoor Conditions	Pressure	25°C	30°C	35°C	40°C	45°C	50°C
21°C D 15°C W	Pressure ( kg/cm <sup>2</sup> )	7.8	8.1	8.4	9.0	9.3	10.0
24°C D 17°C W	Pressure ( kg/cm <sup>2</sup> )	7.9	8.2	8.7	9.0	9.5	10.1
27°C D 19°C W	Pressure ( kg/cm <sup>2</sup> )	8.0	8.5	9.2	9.9	10.2	10.8
32°C D 23°C W	Pressure ( kg/cm <sup>2</sup> )	8.8	9.1	9.2	10.0	10.5	11.2

Heating mode		OUTDOOR CONDITIONS					
Indoor Conditions	Pressure	12°C D 11°C W	7°C D 6°C W	0°C D -1°C W	-4°C D -6°C W	-7°C D -9°C W	-15°C D -x°C W
15°C	Pressure ( ka/cm <sup>2</sup> )	26.5	25.0	22.0	21.5	20.5	/
18°C	Pressure ( ka/cm <sup>2</sup> )	27.0	26.0	23.5	22.5	20.8	/
20°C	Pressure ( ka/cm <sup>2</sup> )	27.5	26.5	25.0	23.0	21.0	/
22°C	Pressure ( ka/cm <sup>2</sup> )	28.5	27.0	25.5	23.9	21.5	/

5.2 HCNI 352 G

Cooling mode		Outdoor temperature (Dry bulb temp)					
Indoor Conditions	Pressure	25°C	30°C	35°C	40°C	45°C	50°C
21°C D 15°C W	Pressure ( kg/cm <sup>2</sup> )	8.4	8.5	8.8	8.9	9.4	9.9
24°C D 17°C W	Pressure ( kg/cm <sup>2</sup> )	8.6	8.8	9.2	9.4	10.0	10.4
27°C D 19°C W	Pressure ( kg/cm <sup>2</sup> )	8.8	9.2	9.4	9.8	10.3	10.9
32°C D 23°C W	Pressure ( kg/cm <sup>2</sup> )	9.2	9.6	9.9	10.4	10.8	11.2

Heating mode		OUTDOOR CONDITIONS					
Indoor Conditions	Pressure	12°C D 11°C W	7°C D 6°C W	0°C D -1°C W	-4°C D -6°C W	-7°C D -9°C W	-15°C D -x°C W
15°C	Pressure ( ka/cm <sup>2</sup> )	27.4	25.9	22.2	21.4	20.0	/
18°C	Pressure ( ka/cm <sup>2</sup> )	29.8	27.2	23.8	22.0	21.1	/
20°C	Pressure ( ka/cm <sup>2</sup> )	30.2	29.1	24.2	23.6	22.1	/
22°C	Pressure ( ka/cm <sup>2</sup> )	32.4	30.1	25.4	24.0	22.7	/

# 6. Schematic diagram and wiring diagram

## 6.1 Schematic diagram

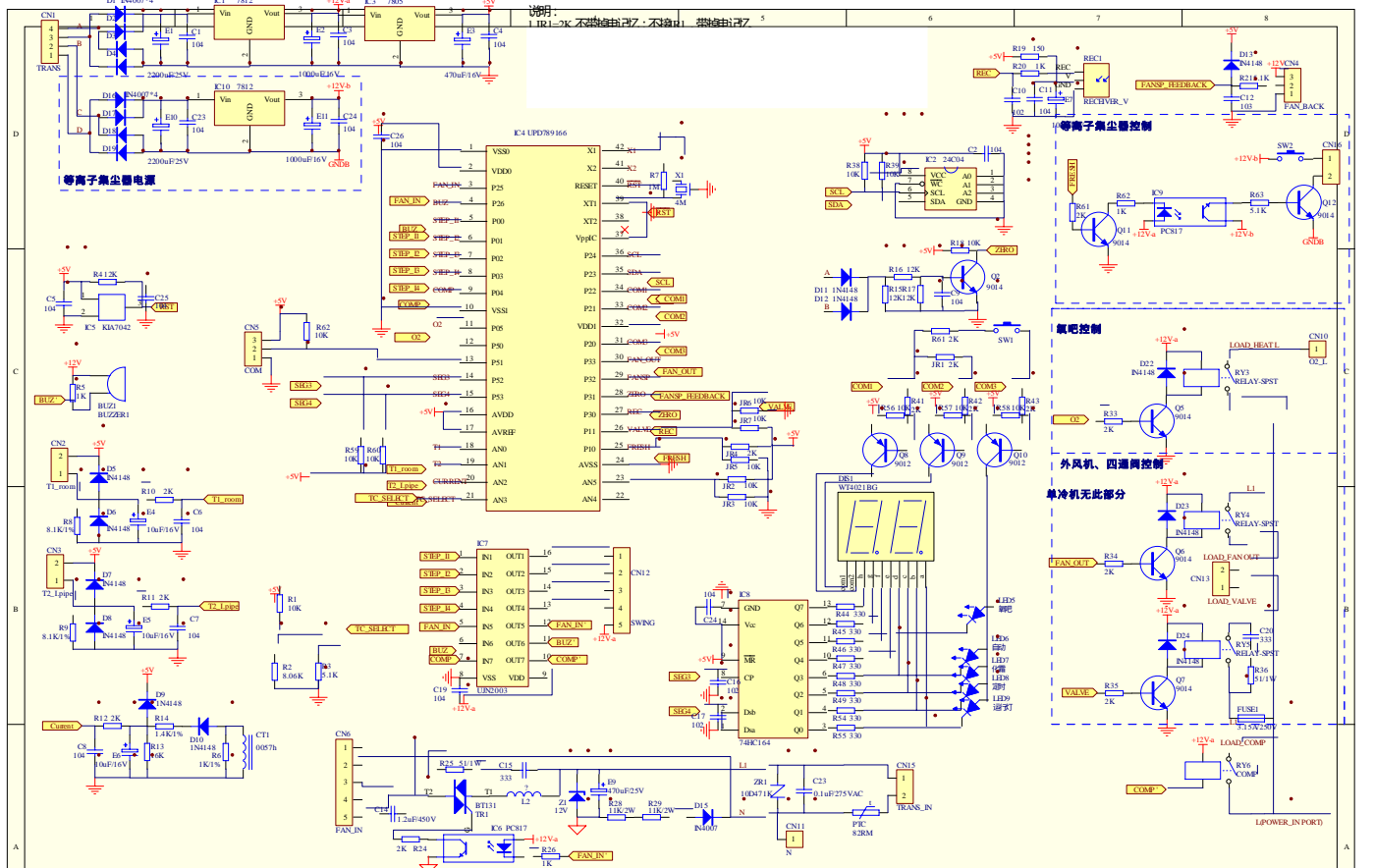

## 6.2.2 Heating/cooling

### 6.2.2.1 HKEI - HCNI 262-352 G

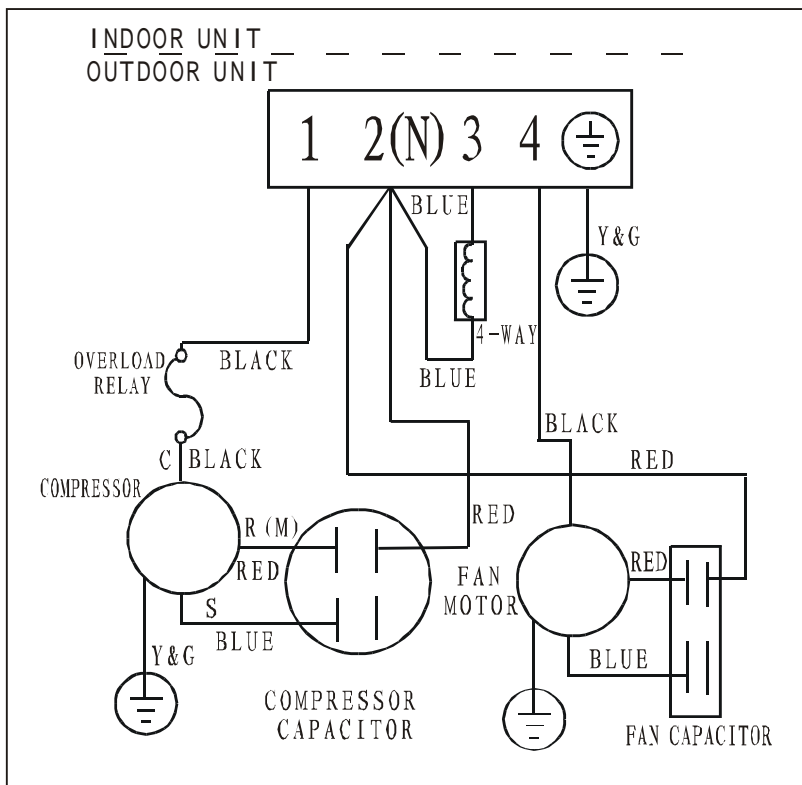
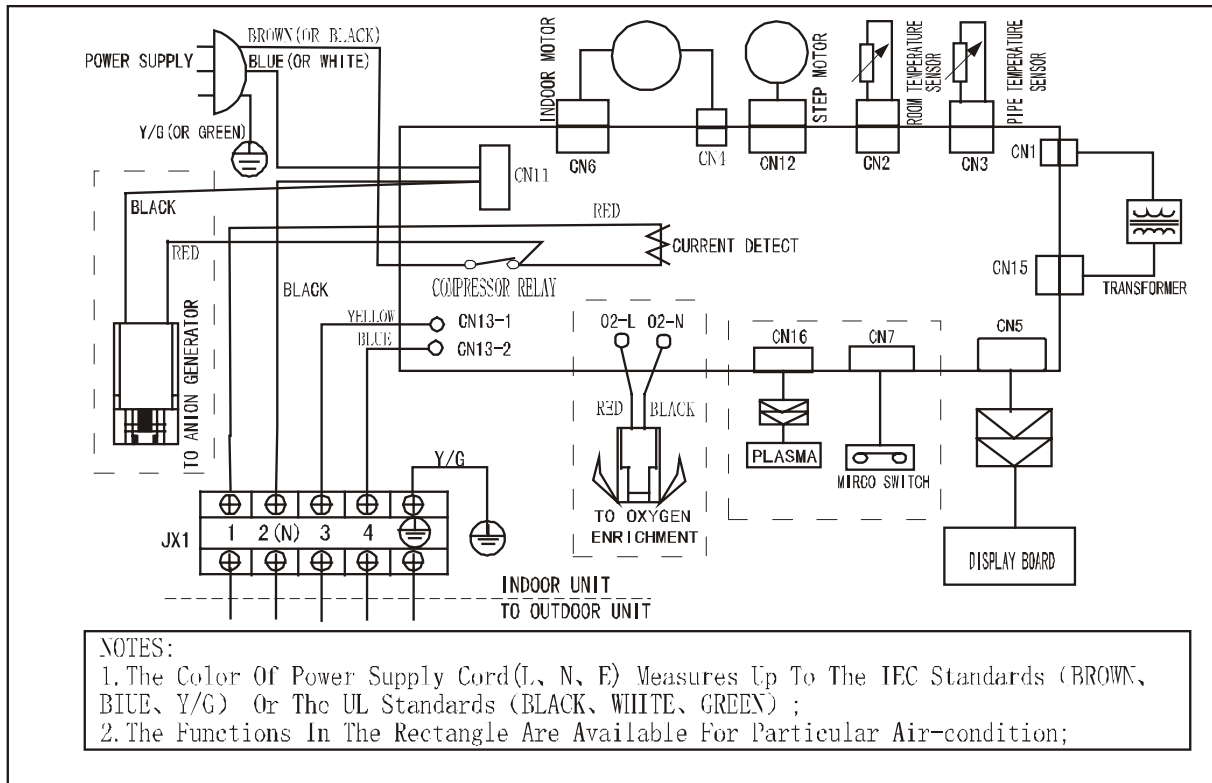

## 8 Electronic function

### 8.1 Electric Control working environment

8.1.1 input voltage: 175~253V

8.1.2 Input power frequency:50Hz

8.1.3 Ambient temperature: -7°C~+43°C

8.1.4 Indoor fan normal working amp is less than 1A,

8.1.5 Outdoor fan. Normal working amp is less than 1.5A

8.1.6 Four-way valve normal working amp is less than 1A.

8.1.7 Swing motor: DC12V.

8.1.8 Compressor: single-phase power supply. Its normal working amp is less than 15A

### 8.2 Proper symbols and their meanings:

TA: Indoor ambient temperature

TE: Indoor evaporator temperature

TS: Setting temperature through the remote controller

I<sub>3sec</sub>: Self-protection amp of compressor, continue three seconds until turns off the compressor.

I<sub>5MIN</sub>: Self-protection amp of compressor, continue five minutes until turns off the compressor.

I<sub>FAN</sub>: Self-protection amp of outdoor fan/indoor fans when they change from higher wind to lower wind.

I<sub>RESTORE</sub>: Amp self-protection return value

TH<sub>DEFROST</sub>: High wind, defrosting temperature difference

TM<sub>DEFROST</sub>: Middle wind, defrosting temperature difference

TL<sub>DEFROST</sub>: Low wind, defrosting temperature difference

TE1: Anti-cold wind, from Fan Off to Breeze temperature

TE2: Anti-cold wind, from Breeze to Setting Fan Speed temperature

TE3: Anti-cold wind, from Setting Fan Speed to Breeze temperature

TE4: Anti-cold wind, from Breeze to Fan Off temperature

TE5: Evaporator low temperature protection entering temperature

TE6: Evaporator low temperature protection restoring temperature

TE7: Evaporator high temperature protection, compressor off temperature

TE8: Evaporator high temperature protection, fan off temperature

TE9: Evaporator high temperature protection, restoring temperature

### 8.3 Functions

Remote receiving

Testing and forced running

Position set for indoor unit wind vane

LED displaying and alarm

On or off Timer

Protection for the compressor

Current protection

High temperature protection of indoor heat exchanger at heating mode

Auto defrosting and heating recovery at heating mode

Anti cold air at heating mode

Anti frozen at cooling mode

## 8.4 Protection

8.4.1 3 minutes delay at restart for compressor.

8.4.2 Sensor protection at open circuit and breaking disconnection

8.4.3 Fan Speed is out of control. When Indoor Fan Speed is too high(higher than High Fan+300RPM)or too low(lower than 400RPM), the unit stops and LED displays failure information and can't returns to normal operation automatically.

8.4.4 Cross Zero signal error warning. If there is no Cross Zero signals in 4 minutes, the unit stops and LED displays failure information and can't returns to normal operation automatically.

8.4.5 The current protection of the compressor

	Condition	Indoor fan	Compressor	Outdoor fan	Remark
Current up	$I < I_{RESTORE}$	On	On	On	
	$I_{RESTORE} < I < I_{FAN}$	On	On	Off	Heating mode
		Low speed	On	On	On
	$I_{FAN} < I < I_{5MIN}$		Off	Off	After 5 Minutes
	$I_{5MIN} < I < I_{3SEC}$		Off	Off	After 3 Seconds
Current down	$I_{5MIN} < I < I_{3SEC}$		Off	Off	After 3 Seconds
	$I_{FAN} < I < I_{5MIN}$		Off	Off	After 5 Minutes
	$I_{RESTORE} < I < I_{FAN}$	On	On	Off	Heating mode
		Low speed	On	On	On
	$I < I_{RESTORE}$	On	On	On	

If compressor turns off for continuously 4 times due to current protection in 5 minutes from Compressor On, the unit stops and LED displays failure information and can't returns to normal operation automatically.

## 8.5 Fan-only mode

Fan speed is high/mid/low/ Auto

## 8.6 Cooling mode

The 4-way valve is closed at cooling mode.

The action of the compressor and the outdoor fan:

	Condition T=Indoor Temp. Ts=Setting Temp.	Compressor	Outdoor fan
Room temp. up	$T > Ts+1$	On	On
	$T < Ts+1$	Off	Off
Room temp. down	$T > Ts$	On	On
	$T < Ts$	Off	Off

Auto fan at cooling mode:

	Condition T=Indoor Temp.-Setting Temp.	Indoor fan speed
Room temp. up	$T < 4$	Low
	$4 < T < 5$	Med.
	$T > 5$	High
Room temp. down	$T > 4$	High
	$1 < T < 4$	Med.
	$T < 1$	Low

Anti-freezing control to indoor evaporator at cooling mode( T: evaporator temp. )

	Condition		Compressor	Outdoor fan
	Temp.	Time		
Evaporator Temp. up	T > TE6		On	On
	T < TE6	>5 Minutes	Off	Off
Evaporator Temp. down	T > TE5		On	On
	T < TE5	>5 Minutes	Off	Off

## 8.7 Dehumidifying mode

8.7.1 The 4-way valve is off in dehumidifying mode

8.7.2 Compressor and Indoor Fan actions in dehumidifying mode

NO	Conditions	Indoor Fan	Compressor and Outdoor Fan
1	$TA \geq TS+2$	LOW BREEZE	ON 6minutes OFF 4minutes
2	$TS \leq TA < TS+2$	LOW BREEZE	ON 5minutes OFF 5minutes
3	$TA < TS$	LOW BREEZE	ON 4minutes OFF 6minutes

Repeat on and off cycle.

8.7.3 Low room temperature protection:

When room temperature decreases to below 10 , compressor and outdoor fan will stop(indoor fan is Breeze). Dehumidifying operation will be resumed when room temperature restores to over 13 .

8.7.4 At dehumidifying mode, the anti-freezing function of the indoor heat exchanger is the same as that of cooling mode.

8.7.5 At dehumidifying mode, the action of fans of indoor is the same as that of air-only mode.

8.8 Heating mode

8.8.1 Generally, the 4-way valve is open in heating mode, but it is closed in defrosting mode. 4-way valve must delay 2 minutes compared with compressor if the compressor changed into non-heating mode or turned off. 4-way valve doesn't delay in dehumidifying mode.

8.8.2 Generally, the outdoor fan is turned off with the on-off action of compressor in heating mode, except for the defrosting mode or the end of defrost.

8.8.3 Action of compressor and outdoor fan motor at heating mode: compressor must run for 7 minutes after starting and then judge temperature. Meanwhile other protections are still valid.

	Condition	Compressor	Outdoor fan
Room temp. up	$T > T_s + 3^*$	Off	Off
	$T < T_s + 3^*$	On	On
Room temp. down	$T < T_s + 2^*$	On	On
	$T > T_s + 2^*$	Off	Off

\* This parameter can be changed from 0 to 3.

8.8.4 Indoor Fan actions at heating mode

Indoor Fan can be set at HIGH/MID/LOW/AUTO by using a remote controller, but Anti-cold wind function prevails.

Optional 1:

Anti-cold wind control function at heating mode

	Condition T= Indoor exchanger temp.	Indoor fan speed
Indoor exchanger temp. up	$T < TE1$	Off
	$TE1 < T < TE2$	Breeze
	$T > TE2$	Setting fan speed
Indoor exchanger temp. down	$T > TE3$	Setting fan speed
	$TE3 < T < TE4$	Breeze
	$T < TE4$	Off

Option 2:

Indoor fan changes breeze when compressor stop, after 127 second, indoor fan stop.

8.8.5 Auto wind at heating mode

	Condition T=Indoor Temp.-Setting Temp.	Indoor fan speed
Room temp. up	$T < 2$	High
	$T > 2$	Med.
Room temp. down	$T > 0$	Med.
	$T < 0$	High

8.8.6 Indoor evaporator high-temperature protection at heating mode

	Condition T= Indoor exchanger temp.	Compressor	Outdoor fan
Indoor exchanger temp. up	T<TE8	On	On
	TE8<T<TE7	On	Off
	T>TE7	Off	Off
Indoor exchanger temp. down	T>TE9	Off	Off
	T<TE9	On	On

8.8.7. The louver opens to Standard Angle ANGLHEAT when power is on for the first time

8.9 Defrosting operation (Available for heating only).

8.9.1 Defrosting condition: Defrosting starts when either of the following & :

A and B are satisfied:

A: The compressor keeps running for 40 minutes or more.

B: The temperature difference of evaporator and room temperature meets one of the following:

	Temp. of evaporator---room temp.
Fan speed is high	$\leq TH_{DEFROST}$
Fan speed is mid	$\leq TM_{DEFROST}$
Fan speed is low	$\leq TL_{DEFROST}$
Breeze	Meet only if it is Breeze

Calculate from the end of latest defrost, evaporator high temp. protection only closes outdoor fan with the compressor still running. Add up to 90 minutes.

8.9.2 Defrosting time

If the temp. difference condition is satisfied for less than 40 minutes, this can be regarded as severe frosting. The defrosting time is 10 minutes.

If the temp. difference condition is satisfied for more than 40 minutes, the defrosting time is 6 minutes.

If the temp. difference condition is satisfied out of 40 minutes, generally the defrosting time is 6 minutes, after three continuous 6-minute defrost, the fourth should be 10 minutes defrost. The circulation is as following:

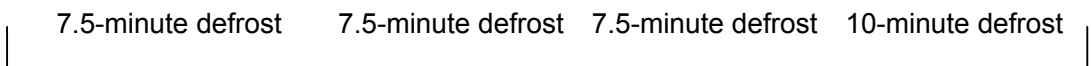

8.9.3 Ending condition of defrosting

If one of following conditions is satisfied, end the defrost and turn into heating mode:

A. The defrost time has reached to 7.5 or 10 minutes.

B. The compressor current has reached to  $I_{DEFROST}$  or above,  $I_{DEFROST}$  differs in different models.

8.9.4 Defrosting Actions:

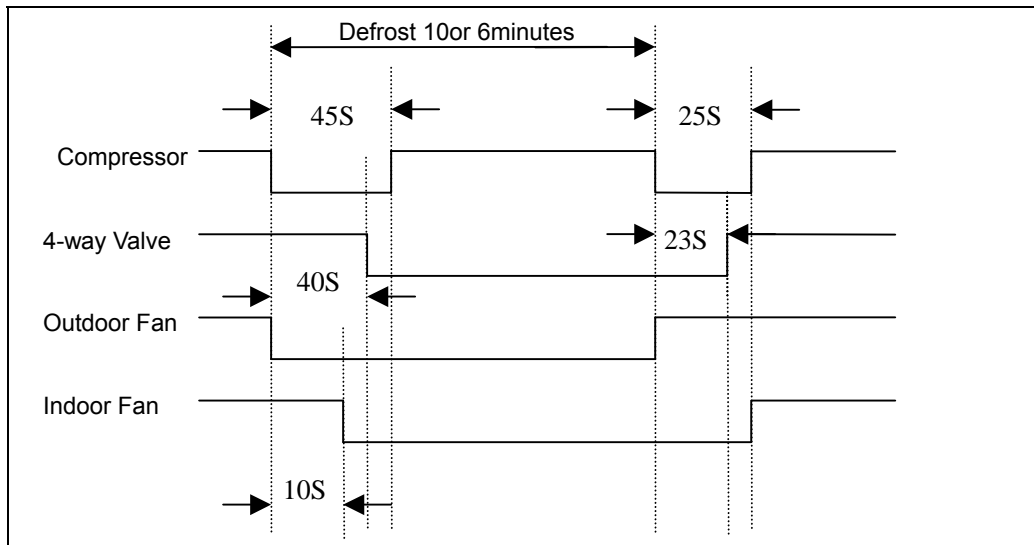

8.10 Automatic operation mode

8.10.1 The air conditioner automatically selects one of the following operation modes: cooling, heating or fan only according to the temp. difference between room temp. (TA) and set temp. (TS).

TA—TS	Operation mode
TA—TS>2	Cooling
-1 ≤TA-TS≤+2	Fan-only
TA-TS<-1	Heating (air-only for cooling only type)

8.10.2 The indoor fan blows automatically in corresponding selected mode.

8.10.3 The motion of indoor fan’s blade should accord with the selected operation mode.

8.10.4 One mode should be carried out for at least 15 minutes once selected. If the compressor cannot start for 15 minutes, reselect the operation mode according to the room temp. and set temp., or reselect when the set temp. varies.

8.11 Forced cooling function

8.11.1 Select forced cooling function with the forced cooling button or the switch.

8.11.2 The compressor is unconditionally turned on, after 30 minutes cooling operation whose fan mode is set as low, the A/C operates at the DRY mode with a set temp. of 24 .

8.11.3 All protections of remote control cooling are available at forced cooling operation.

8.12 Forced Auto function

Select forced auto function with the forced auto button or the switch.

In forced auto status the A/C operates at remote control mode with a set temp. of 24 .

8.13 Timer Function

8.14 Sleep mode

8.14.1 The sleep function is available at cooling, heating or auto mode.

8.14.2 Cooling:

The set temperature rise 1 per hour. Two hours later, the set temperature will maintain as a

constant and the fan speed is kept at low speed.

The total time is 7 hours, after 7 hours the unit stops.

8.14.3 Heating:

The set temperature decrease 1 per hour. Two hours later, the set temperature will maintain as a constant and the air circulation is kept at low speed (Cold air proof function takes precedence over all).

The total time is 7 hours, after 7 hours the unit stops.

8.14.4 Auto:

The economic running function operates in accordance with selected running mode by auto mode.

The total time is 7 hours, after 7 hours the unit stops.

8.15 Auto restart function

In case of a sudden power failure, this function automatically sets the unit to previous settings before the power failure when power returns.

8.16 PLASMA ( optional):

Starts with indoor fan.

Note: Plasma and Anion can be use together.

8.17 Anion (optional)

Starts with indoor fan.

Note: Plasma and Anion can be use together.

## 9. Troubleshooting

### 9.1 Display board

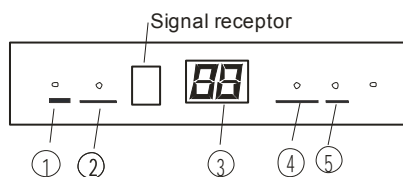

- ① **AUTO indicator**  
This indicator illuminates when the air conditioner is in AUTO operation.
- ② **DEFROST indicator (For Cooling & Heating models only)**  
This indicator illuminates when the air conditioner starts defrosting automatically or when the warm air control feature is activated in heating operation.
- ③ **TEMPERATURE indicator**  
Displays the temperature settings when the air conditioner is operational.
- ④ **OPERATION indicator**  
This indicator flashes after power is on and illuminates when the unit is in operation.
- ⑤ **TIMER indicator**  
This indicator illuminates when TIMER is set ON/OFF.

### 9.2 For all heat pump model

Failure phenomenon	Operation lamp	Timer lamp
Indoor fan speed has been out of control for over 1 minute		X
Indoor room temp. or evaporator sensor is open circuit or short circuit		On
Over current protection of the compressor occurs 4 times	X	
EEROM error	On	
No over-zero signal		

- ✕ Extinguish  
Flash at 5Hz

### 9.3 Diagnostic Chart

#### 9.3.1 After energizing, no indicator is lighted and the air conditioner can't be operated.

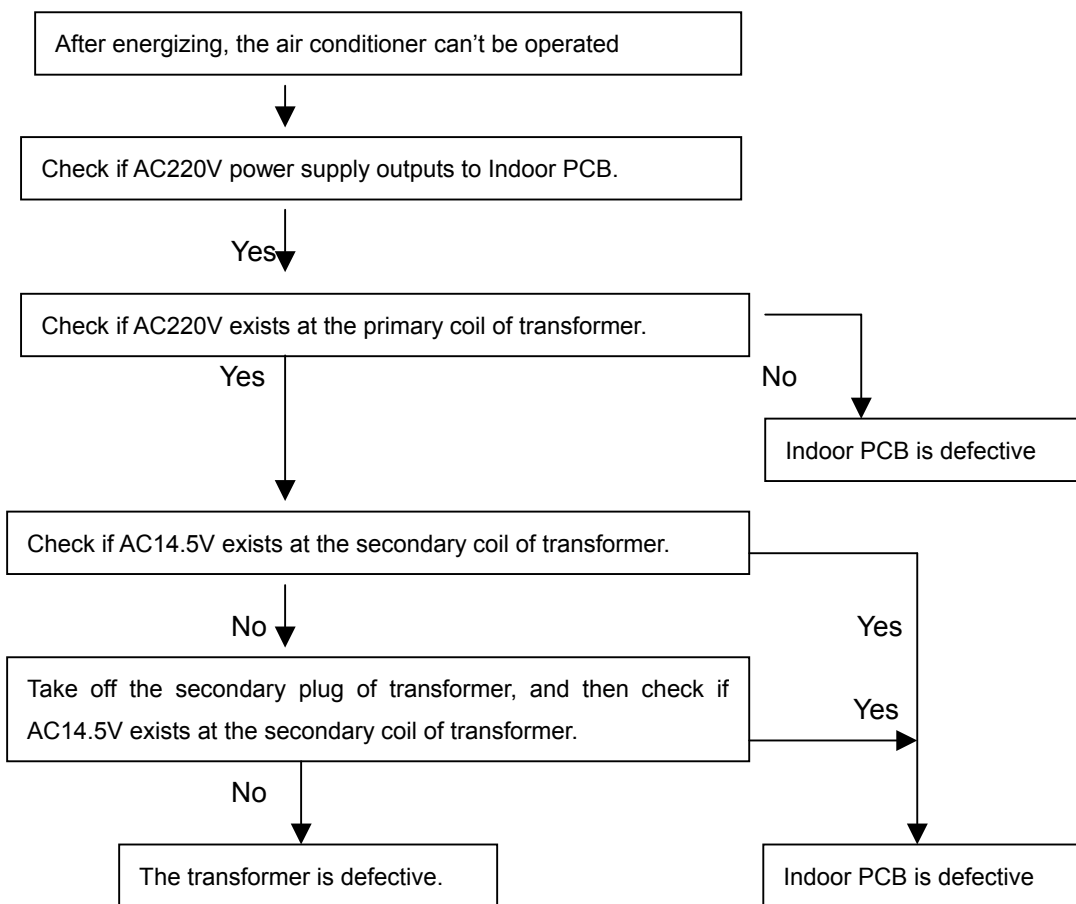

#### 9.3.2 Resetting phenomenon often occurs during operation. (That is automatically entering to the status when power is on.)

The reason is that the instantaneous voltage of main chip is less than 4.5V. Check according to the following procedure:

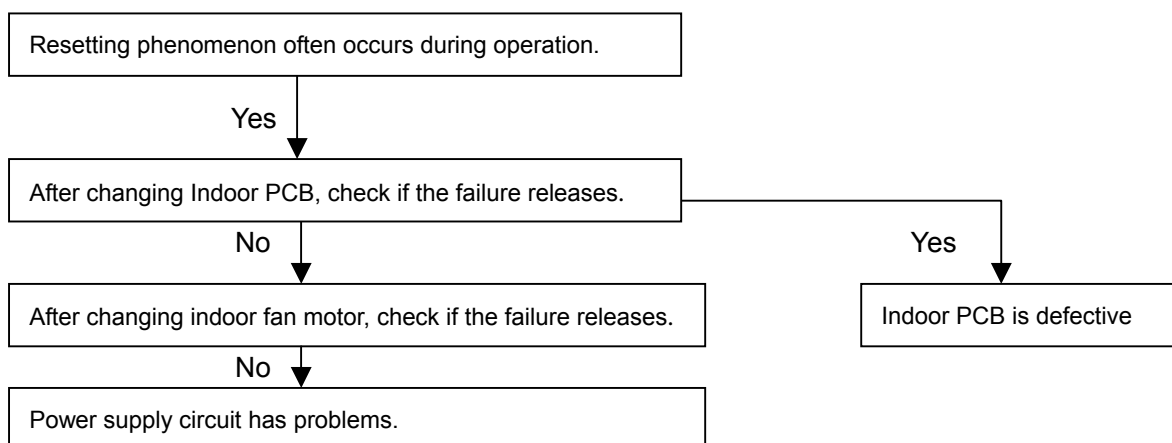

### 9.3.3 Failure phenomenon

Failure phenomenon	Operation lamp	Timer lamp
Indoor fan speed has been out of control for over 1 minute		X
Indoor room temp. or evaporator sensor is open circuit or short circuit		On
Over current protection of the compressor occurs 4 times	X	
EEROM error	On	
No over-zero signal		

✕ Extinguish  
Flash at 5Hz

#### 9.3.3.1 Operation lamp flashes and Timer lamp off.

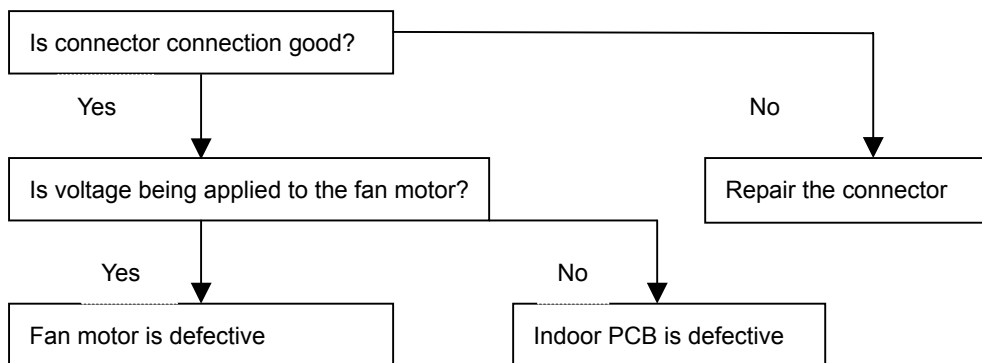

#### 9.3.3.2 Operation lamp flashes and Timer lamp on.



#### 9.3.3.3 Operation lamp off and Timer lamp flashes

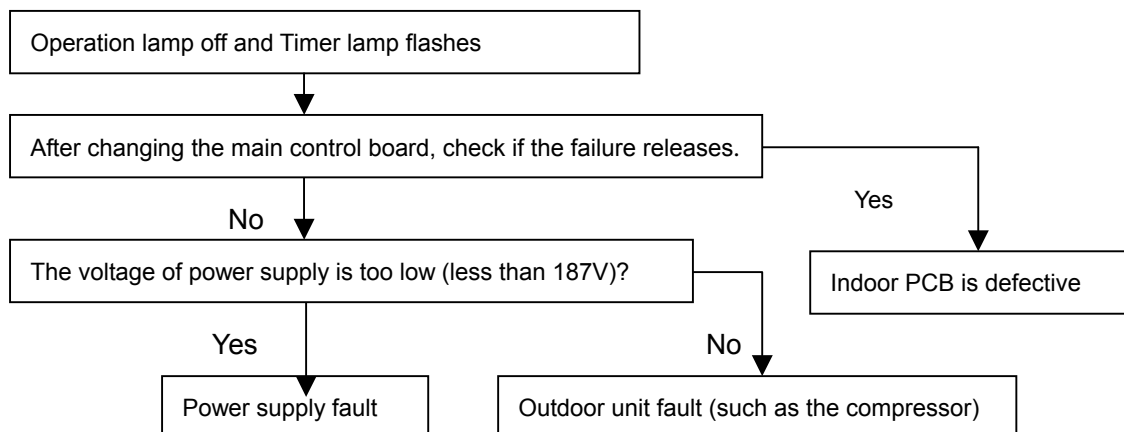

#### 9.3.3.4 Operation lamp on and Timer lamp flashes

EEROM error, indoor PCB is defective.

#### 9.3.3.5 Operation lamp flashes, Timer lamp flashes .

This is alarm signal when the main chip can't detect over-zero signal. When such failure occurs, the main control board must have fault.

10. Characteristic of temp. sensor

Temp.	Resistance KΩ		Temp.	Resistance KΩ		Temp.	Resistance KΩ
-10	62.2756		17	14.6181		44	4.3874
-9	58.7079		18	13.918		45	4.2126
-8	56.3694		19	13.2631		46	4.0459
-7	52.2438		20	12.6431		47	3.8867
-6	49.3161		21	12.0561		48	3.7348
-5	46.5725		22	11.5		49	3.5896
-4	44		23	10.9731		50	3.451
-3	41.5878		24	10.4736		51	3.3185
-2	39.8239		25	10		52	3.1918
-1	37.1988		26	9.5507		53	3.0707
0	35.2024		27	9.1245		54	2.959
1	33.3269		28	8.7198		55	2.8442
2	31.5635		29	8.3357		56	2.7382
3	29.9058		30	7.9708		57	2.6368
4	28.3459		31	7.6241		58	2.5397
5	26.8778		32	7.2946		59	2.4468
6	25.4954		33	6.9814		60	2.3577
7	24.1932		34	6.6835		61	2.2725
8	22.5662		35	6.4002		62	2.1907
9	21.8094		36	6.1306		63	2.1124
10	20.7184		37	5.8736		64	2.0373
11	19.6891		38	5.6296		65	1.9653
12	18.7177		39	5.3969		66	1.8963
13	17.8005		40	5.1752		67	1.830
14	16.9341		41	4.9639		68	1.7665
15	16.1156		42	4.7625		69	1.7055
16	15.3418		43	4.5705		70	1.6469

## ***CONNECTION OF THE OXYGEN RICH MIXTURE CONTROL***

### **OUTLINE OF OPERATION**

This device, placed on the Outdoor Unit, is made of a pump and of a special partially permeable membrane (Figures 1 and 2).

Outside air is sucked by the pump and is enriched in oxygen through the membrane. The pump also pushes the airflow enriched in oxygen into the room through a transparent flexible pipe.

### **CONNECTION OF THE FLEXIBLE PIPE**

The end of the flexible pipe without the rapid joint device must be connected to the blue rapid joint situated on the right side of the Outdoor Unit (see Fig.3).

The end of the flexible pipe which is provided with the rapid joint device must be connected to the piece of the transparent flexible pipe situated on the rear side of the Indoor Unit.

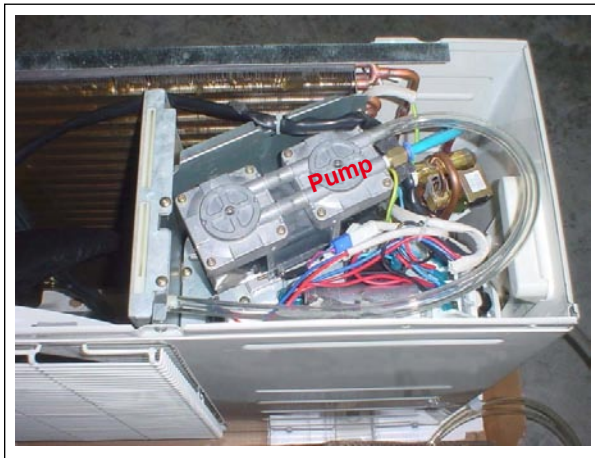

Figure 1

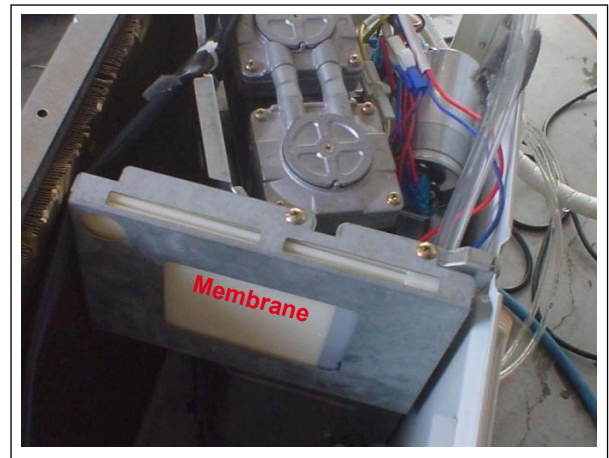

Figure 2



Figure 3

### **WARNING:**

- The partially permeable membrane must be periodically replaced as to avoid being obstructed by dust and dirt - which may compromise the performance of the oxygen rich mixture control device.
- Take particular care not to press or bend the oxygen flexible pipe along its way towards the Indoor Unit.
- The standard length of the flexible pipe (6 metres) can be modified according the installation needs.

### **POWER SUPPLY OF THE OXYGEN RICH MIXTURE CONTROL DEVICE**

The oxygen rich mixture control's pump, placed on the Outdoor Unit, is powered by the Indoor Unit. On the Indoor Unit there is a special black cable with two connectors, which length is suitable for almost all installation needs. This cable ends by a white rapid joint connector, which must be connected to the corresponding connector of same colour and type - which can be seen by removing the cover of terminal board on Outdoor Unit.